

APPLICATION:	PRODUCT NAME: EXPOSED PIPING REEL RINSE INSTALLATION KIT
--------------	--

JOB NAME:	<input type="checkbox"/> SPECIAL CONFIGURATION <input type="checkbox"/> CHECK BASE MODEL AND OPTIONS
-----------	---

QUANTITY:	ITEM NO.	MODEL: ■ 29475
-----------	----------	-------------------

#14443 - VACUUM BREAKER	OPTIONS OR MODIFICATIONS: <input type="checkbox"/> OTHER _____
-------------------------	---

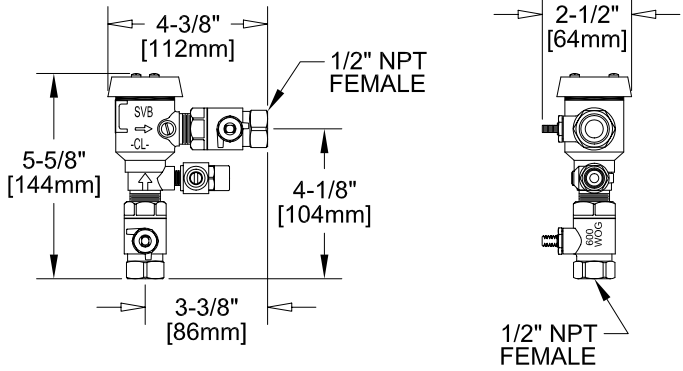

#17639 - CONTROL VALVE	FEATURES
------------------------	----------

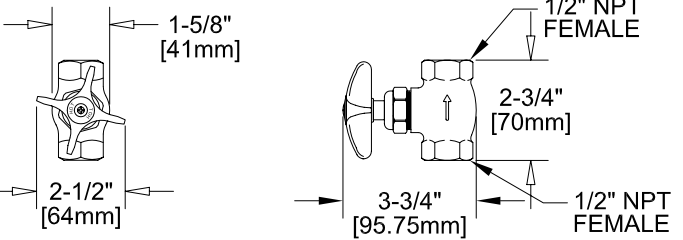

#2936-9000 - CHECK VALVE	KIT INCLUDES THE FOLLOWING #14443 - VACUUM BREAKER (QTY: 1) #2936-9000 - CHECK VALVE (QTY: 2) VACUUM BREAKER * ANTI-SPILL DESIGN * ASSE - 1056 APPROVED
--------------------------	--

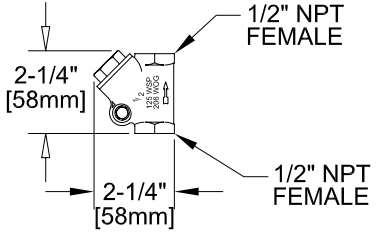

RECOMMENDED LAYOUT**	CONTROL VALVE * INTERNAL SPRING LOADED CHECK VALVES * SWIVELLING SEAT DISKS * RIGHT HAND SWIVEL STEM WITH CROSS HANDLES * STAINLESS STEEL SEATS * STAINLESS STEEL SEAT SCREWS * STAINLESS STEEL HANDLE SCREWS * BLUE AND RED INDEX BUTTONS INCLUDED
----------------------	--

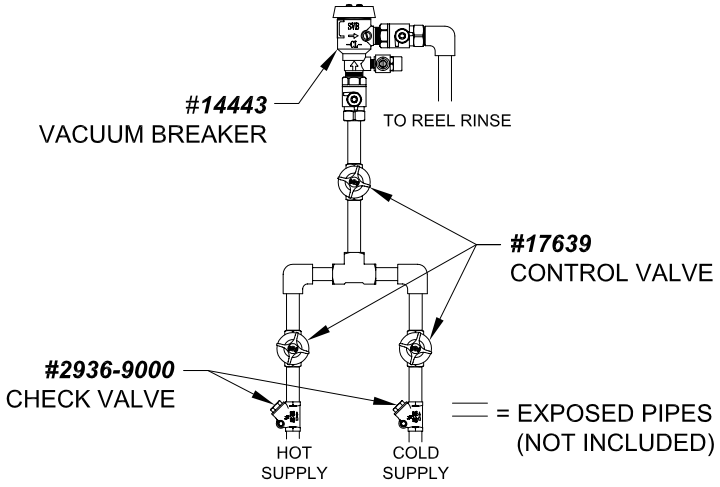

CHECK VALVE * BRASS BODY * ALLOWS FLUID FLOW IN 1 DIRECTION ONLY	SYSTEM LIMITS * TEMP: 40°F MIN. TO 140°F MAX. * PRESSURE: 150 PSI MAX STATIC
SHIPPING WEIGHT * 7.5 LBS ** PIPES, ELBOWS AND TEES NOT INCLUDED	